



EN

Retrofit option

ON Trolley Picomig

Trolley Picomig 180 with holder for 300 mm wire spool

099-000312-EW501

Observe additional system documents!

01.10.2020

**Register now
and benefit!
Jetzt Registrieren
und Profitieren!**

www.ewm-group.com



General instructions

WARNING



Read the operating instructions!

The operating instructions provide an introduction to the safe use of the products.

- Read and observe the operating instructions for all system components, especially the safety instructions and warning notices!
- Observe the accident prevention regulations and any regional regulations!
- The operating instructions must be kept at the location where the machine is operated.
- Safety and warning labels on the machine indicate any possible risks. Keep these labels clean and legible at all times.
- The machine has been constructed to state-of-the-art standards in line with any applicable regulations and industrial standards. Only trained personnel may operate, service and repair the machine.
- Technical changes due to further development in machine technology may lead to a differing welding behaviour.

In the event of queries on installation, commissioning, operation or special conditions at the installation site, or on usage, please contact your sales partner or our customer service department on +49 2680 181-0.

A list of authorised sales partners can be found at www.ewm-group.com/en/specialist-dealers.

Liability relating to the operation of this equipment is restricted solely to the function of the equipment. No other form of liability, regardless of type, shall be accepted. This exclusion of liability shall be deemed accepted by the user on commissioning the equipment.

The manufacturer is unable to monitor whether or not these instructions or the conditions and methods are observed during installation, operation, usage and maintenance of the equipment.

An incorrectly performed installation can result in material damage and injure persons as a result. For this reason, we do not accept any responsibility or liability for losses, damages or costs arising from incorrect installation, improper operation or incorrect usage and maintenance or any actions connected to this in any way.

© EWM AG

Dr. Günter-Henle-Strasse 8
56271 Mündersbach Germany
Tel.: +49 2680 181-0, Fax: -244
Email: info@ewm-group.com
www.ewm-group.com

The copyright to this document remains the property of the manufacturer.

Copying, including extracts, only permitted with written approval.

The content of this document has been prepared and reviewed with all reasonable care. The information provided is subject to change; errors excepted.

1 For your safety

1.1 Safety instructions

WARNING



Do not carry out any unauthorised repairs or modifications!
To avoid injury and equipment damage, the unit must only be repaired or modified by specialist, skilled persons!

The warranty becomes null and void in the event of unauthorised interference.

- Appoint only skilled persons for repair work (trained service personnel)!



Risk of accidents due to non-compliance with the safety instructions!

Non-compliance with the safety instructions can be fatal!

- Carefully read the safety instructions in this manual!
- Observe the accident prevention regulations and any regional regulations!
- Inform persons in the working area that they must comply with the regulations!

These supplementary sheets must be used in conjunction with the appropriate standard operating instructions for the described product! These supplementary sheets expand or replace one or more chapters of the same name(s) in the standard description.

Read and observe the operating instructions for all system components, especially the safety instructions!

2 Intended use

2.1 General

WARNING



Hazards due to improper usage!

The machine has been constructed to the state of the art and any regulations and standards applicable for use in industry and trade. It may only be used for the welding procedures indicated at the rating plate. Hazards may arise for persons, animals and material objects if the equipment is not used correctly. No liability is accepted for any damages arising from improper usage!

- The equipment must only be used in line with its designated purpose and by trained or expert personnel!
- Do not improperly modify or convert the equipment!

2.2 Applications

Use the option described below to add a trolley to the welding machine and the option to work with 300-mm wire spools.

These instructions apply only for the conversion of the following machines:

- Picomig 180

2.3 Short description of the working steps required

- Drill a hole with 20 mm Ø into the welding machine.
- Screw the wire feed nipple into the bore.
- Fix the welding machine to the trolley.
- Final inspection.

3 Conversion

3.1 General

⚠ DANGER



Risk of injury from electric shock!

Servicing machines that are not disconnected from the mains can lead to serious injuries!

- Disconnect the machine completely from the mains.
Pull out the mains plug!
- Wait for 4 minutes until the capacitors have discharged!

3.2 Parts list

Before conversion, check that the retrofit kit is complete (see parts list).

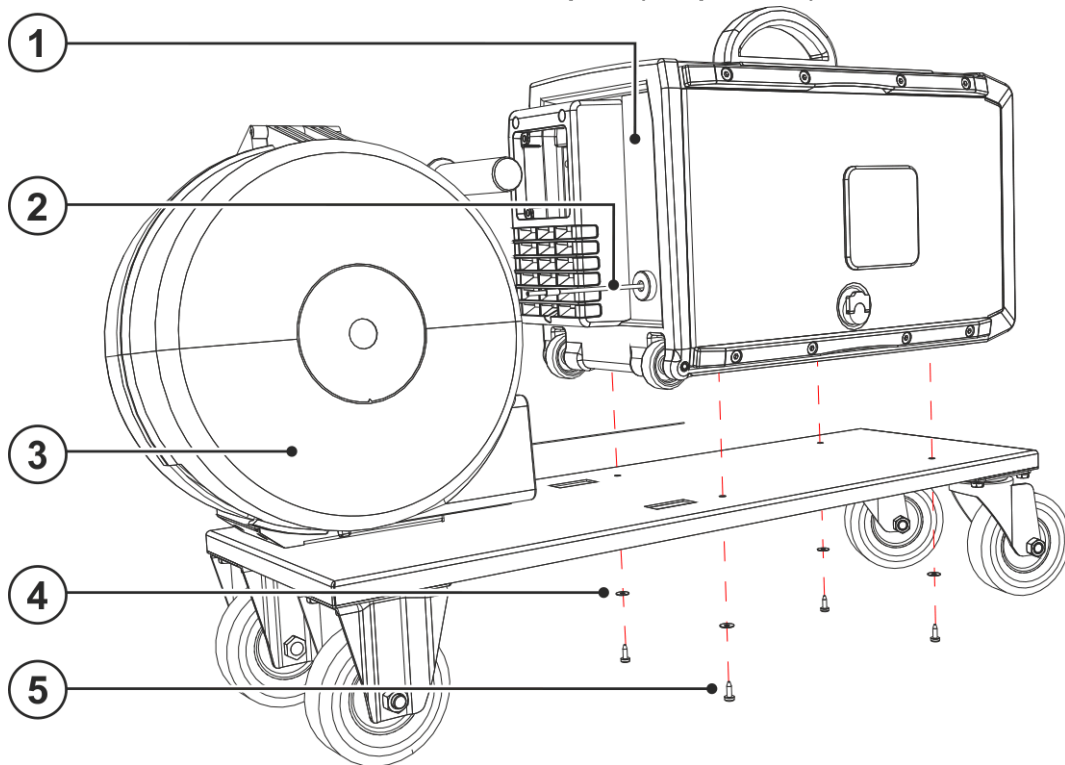

Figure 3-1

Item	Quantity	Description	Item number
1	1	Drilling template	094-015786-00000
2	1	Wire guide/wire feed	092-002671-E0000
3	1	ON Trolley Picomig Trolley Picomig 180 with holder for 300 mm wire spool	092-000312-00000
4	4	Disk spring M5	064-000751-00000
5	4	Threaded grooved pin M5 x 16	094-015135-00000

3.3 Assembly

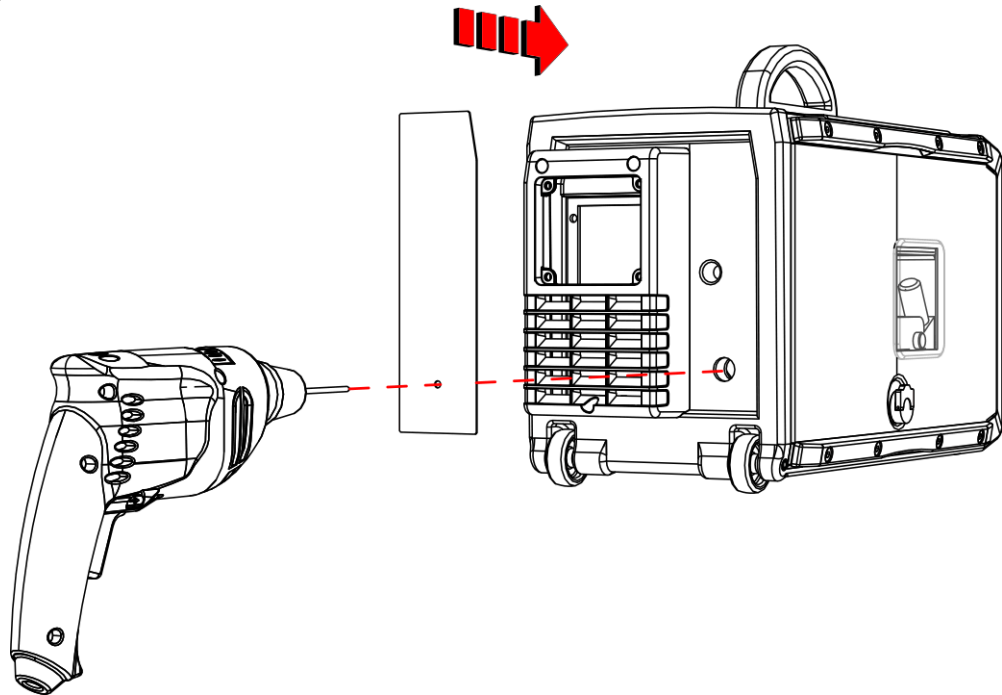

Figure 3-2

- Place the drilling template against the machine as shown in the figure.
- Pre-drill a hole with a diameter of 4 mm.
- Remove drilling template.
- Drill again to enlarge the bore to a diameter of 20 mm.
- Burr the bore.

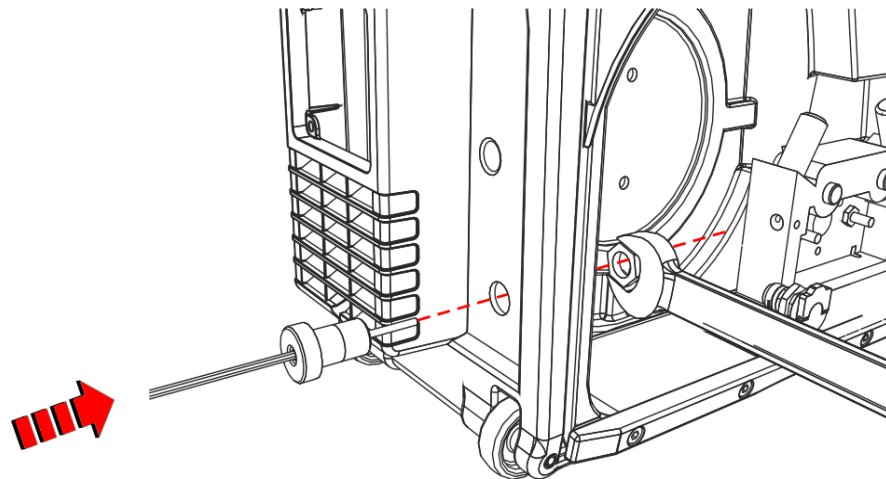

Figure 3-3

- Screw the hexagon nut off the wire feed.
- Insert the wire feed through the bore.
- Lock the wire feed with the hexagon nut.

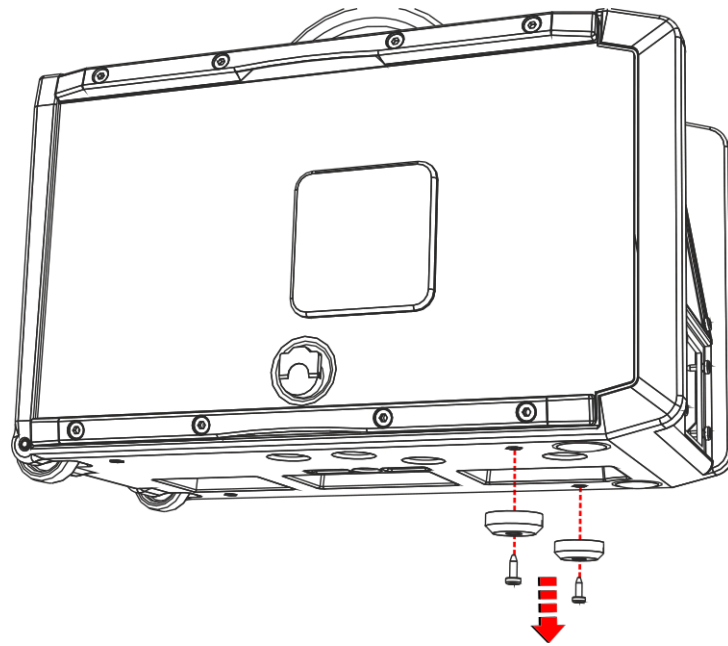

Figure 3-4

- Remove unit feet.

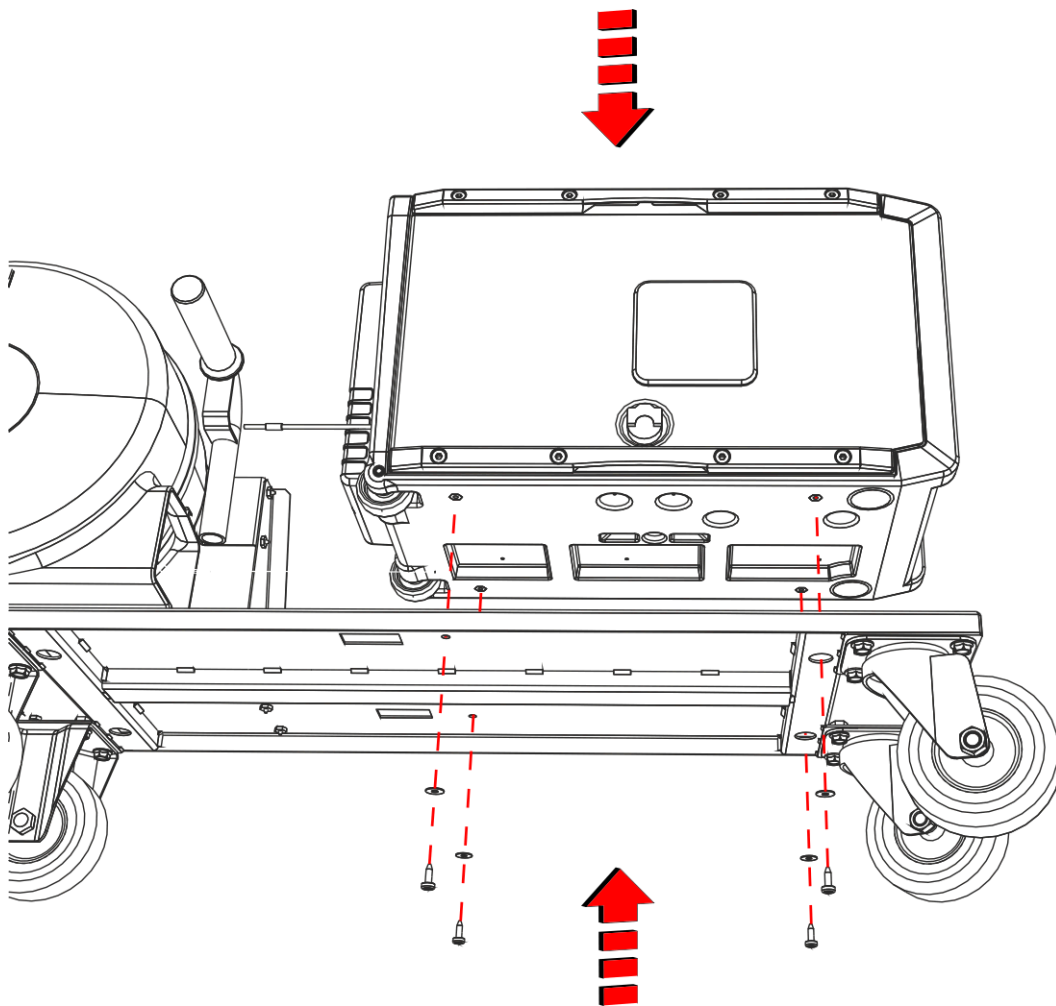

Figure 3-5

- Place the welding machine (see figure) onto the trolley.
- Fix the welding machine to the transport vehicle using 4 threaded grooved pins and disk springs.

3.4 Final inspection **WARNING**

Danger due to failure to carry out the final inspection!

Parts that are incorrectly fitted or that become loose are a source of danger.

- Check all mechanical connections to ensure that they are fitted correctly!
- Carry out the final inspection!
- Carry out the functional test!

Keep the conversion instructions with the machine documentation!

When ordering spare parts, ensure that the item number and serial number of the machine are quoted!